

Underground Railroad BOM

Month 2

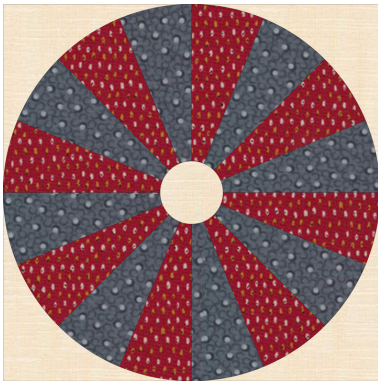

Wagon Wheel Block



12 1/2" square

According to the book *Hidden in Plain View*, the Wagon Wheel block was the second quilt displayed. This pattern instructed the slaves to gather all the tools they would need on their journey to freedom.

Materials:

-  (1) 10" square of Color A
-  (1) 10" square of Color B
- (1) 12 1/2" square of background
- (1) 4" square background for wheel center
- Heat N Bond or any fusible web

1. Cut (2) 10" squares of Heat-N-Bond and (1) 4" piece of Heat-N-Bond.
2. Iron the 10" squares of Heat-N-Bond to the **wrong** side of each 10" fabric square. Repeat the process for the 4" square. Do not remove paper.
2. Trace the wedge template onto the paper side of the Heat-N-Bond. You will need to trace a total of 8 templates onto Color A, 8 templates onto Color B, and 1 circle template to 4" background. Carefully cut out your pieces on the drawn lines. Remove the paper backing.
3. Take a water/air soluble pen, draw a line down the center of your 12 1/2" square ---lengthwise and crosswise (Fig. 1) These lines are used to help center your template pieces on the block. You can also fold your square in half lengthwise, then crosswise, and iron creases in fabric to use as guidelines.



(Fig. 1)

4. Begin placing your template pieces onto the background square. The shiny side is placed onto the right side of the background square. Alternate A and B pieces, until you have formed a complete circle (see photo at top of page for reference).
5. Once you are happy with the placement, put the background circle in the center, on top of the wedge pieces. The circle will cover the tips of the wedge pieces slightly.
6. Iron baste. Carefully place your iron on different areas of your block for a few seconds at a time to baste your pieces in place. (do not rub back and forth) Continue placing your iron in different spots until your pieces are fully adhered to the fabric.

That's it, you're done!



TEMPLATES

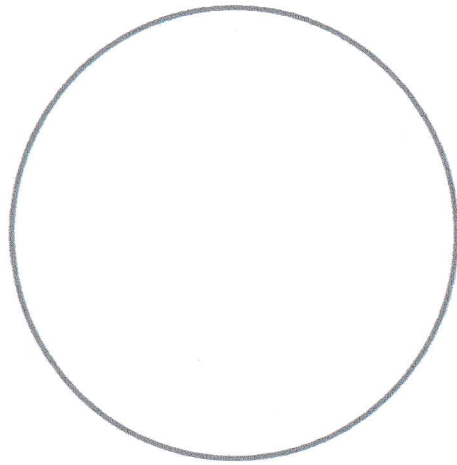

cut 1

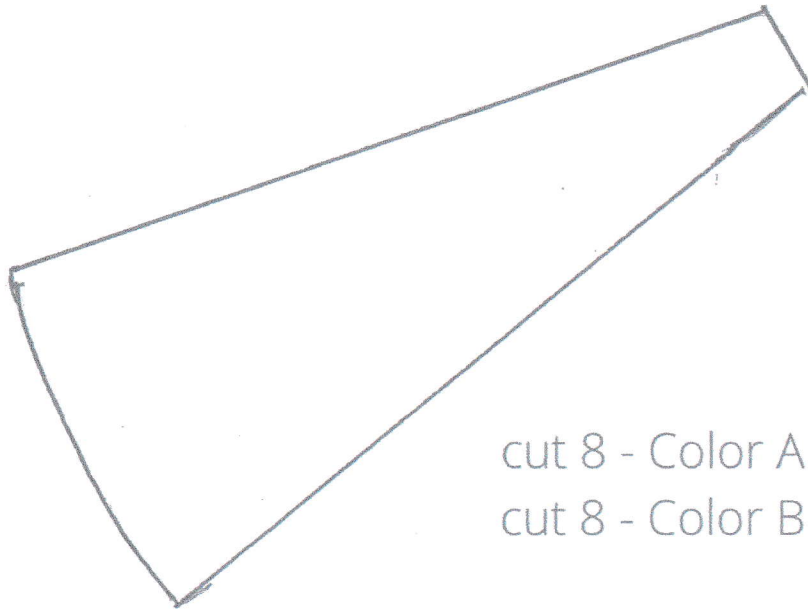

cut 8 - Color A

cut 8 - Color B